

FTTx Optical Receiver Module (ORM)



Key Features

- Provides Fully Autonomous Current-to-Voltage Transimpedance for FTTx Optical Receivers
- Transimpedance Gain of 500 to >10k Ω from +3 to -15 dBm Optical Input Power
- Constant Vout and RF Pout as Photo Diode Current Varies (Duet Patents Pending)
- No Feedback Loop or Voltage Variable Attenuator (VVA) Required
- EINC ≤ 2.0 pA/Square-Root-Hertz (@ 87 to 1000 MHz, -15 dBm Optical Input Power)
- Constant Cascadable RF Output of +23 dBmV/channel, 87 to 1000 MHz (Differential)
- 75-Ohm Differential RF Output (Single-Ended Optional)
- +5 Vdc Single Supply at 135 mA (MER > 37 dB) with +12 Vdc Single Supply at 100 mA OPTIONAL
- User Adjustable Current versus Linearity (+5 Vdc @ 185 mA improves MER to > 40 dB)
- Output Return Loss is 20 dB minimum, 87 to 1000 MHz (with 1:1 balun on RF output)
- Unconditionally Stable
- Compliant to State Administration of Radio and Television (SART) and CableLabs DOCSIS® 3.1 (D3.1) FTTH and HFC Optical Link Standards
- QFN-16 3mm x 3mm SMT Package

Product Description

The DTA0002 is a self-contained optical receiver module (ORM) that provides a constant output voltage and constant RF output when optical input power is received from -15 to +3 dBm. No feedback loop or voltage variable attenuator (VVA) is required saving the user landed product cost and size. When installed and operating the module is fully autonomous with no external attenuation required. The part is available in a small outline, low profile SMT package.

Applications

- SART and D3.1 Optical Link Standard Compliant FTTH and HFC System Receivers, ONUs, and Nodes
- 75-Ohm Direct-to-Display Optical-to-RF Conversion
- Long Reach FTTx Networks Operating with -15 to +3 dBm Optical Input Power
- Shorter Reach FTTx Networks Requiring Lowest Bit Error Rate (using Current Adjust Option)
- Return Path Optical Receivers (RPORs)

Functional Block Diagram

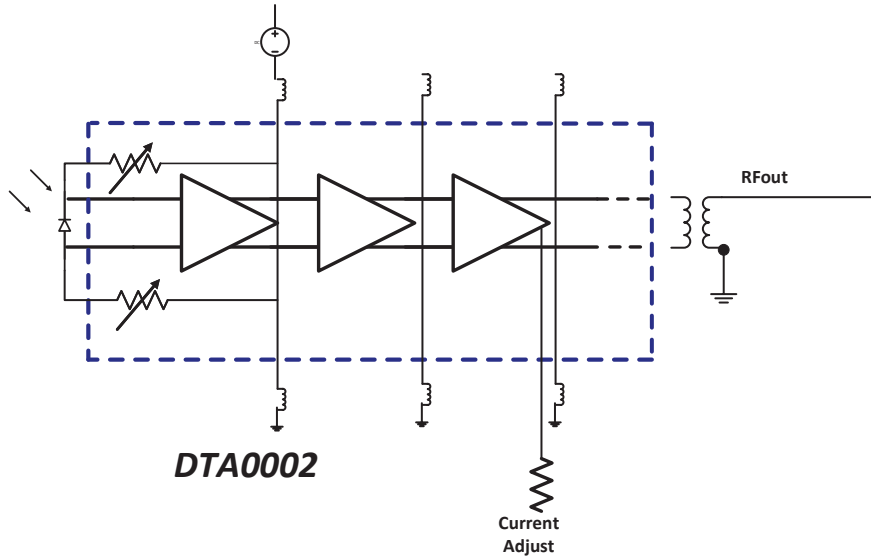

Package Dimensions

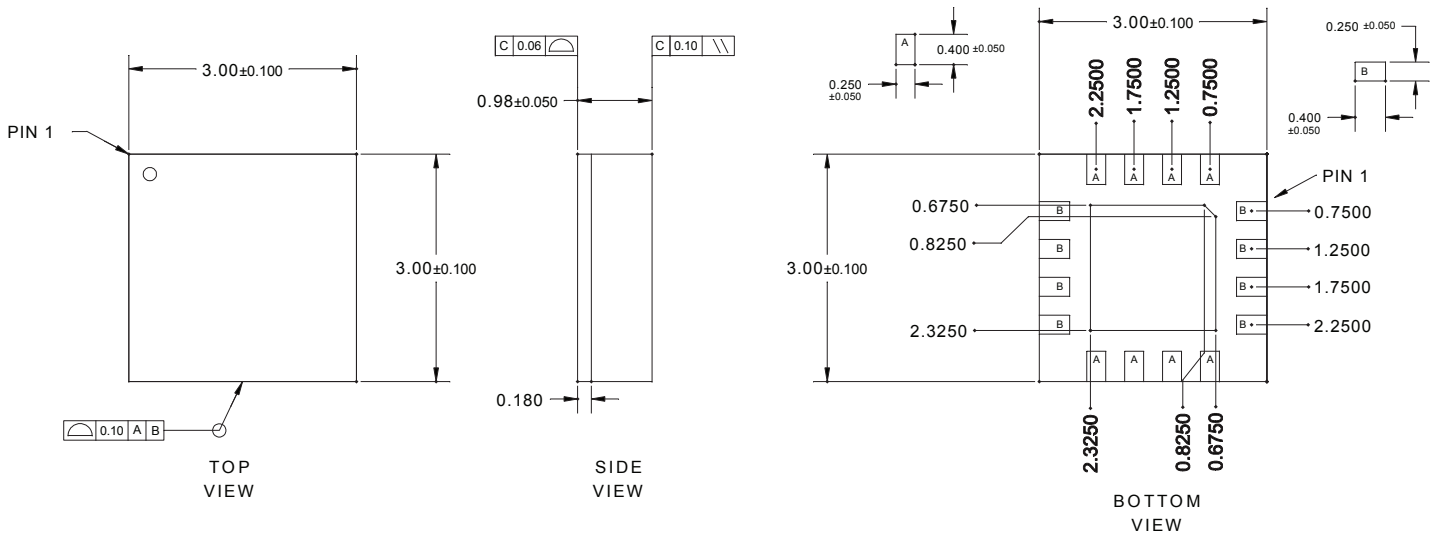

Note: All Dimensions are in millimeters

Package Pin Out

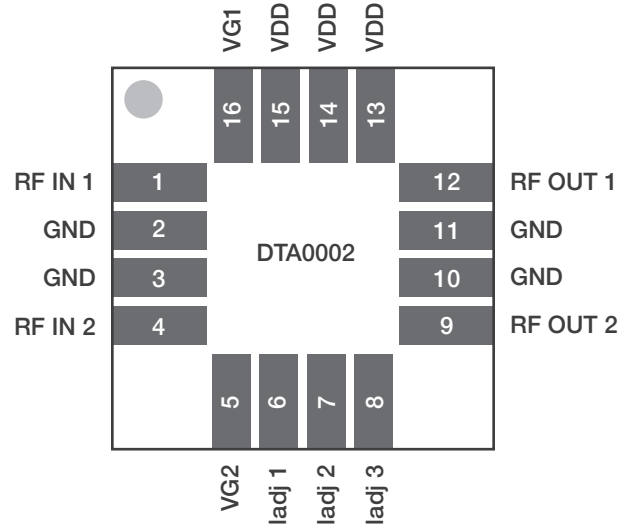

Pin Number	Pin Description	Notes
1	RF In 1 (+)	From Photo Diode Anode (POSITIVE)
2	Ground	(GND)
3	Ground	(GND)
4	RF In 2 (-)	From Photo Diode Cathode (NEGATIVE)
5	VG2	Stage 1 Input Gate Voltage, Inverting ¹
6	ladj 1	TIA Stage 1 Current Adjust via External Resistor Value ²
7	ladj 2	TIA Stage 2 Current Adjust via External Resistor Value ²
8	ladj 3	TIA Stage 3 Current Adjust via External Resistor Value ²
9	RF Out 2 (-)	75-Ohm Differential, Inverting
10	Ground	(GND)
11	Ground	(GND)
12	RF Out 1 (+)	75-Ohm Differential, Non-Inverting
13	Vdd	+5Vdc Input Voltage Shared Across Differential Amplifier Stages ³
14	Vdd	+5Vdc Input Voltage Shared Across Differential Amplifier Stages ³
15	Vdd	+5Vdc Input Voltage Shared Across Differential Amplifier Stages ³
16	VG1	Stage 1 Input Gate Voltage, Inverting ¹

Notes:

1. May be set for a fixed or variable voltage, application specific
2. May be set for a fixed or variable module linearity, application specific
3. +12Vdc VDD operation is OPTIONAL – see Application Circuit below

Absolute Minimum and Maximum Ratings

Parameter	Min	Max	Units
Supply	0	+12	Vdc
Optical Power at the Inputs	-18	+3	dBm
Case Operating Temperature Range, T _C	-40	+110	°C
Storage Temperature	-65	+150	°C
Soldering Temperature	-	+260	°C
Soldering Time	-	5	seconds

Stresses more than the absolute ratings may cause permanent damage. Functional operation is not implied under these conditions. Exposure to absolute ratings for extended periods of time may adversely affect reliability.

Operating Ranges

Parameter	Min	Typ	Max	Units
RF Input/Output Frequency	87		1000	MHz
Supply Voltage		+5	+12	V _{DC}
Case Temperature, T _C	-40	-	+100	°C

The device may be operated safely over these conditions; however, parametric performance is guaranteed only over the conditions defined in the Electrical Specification.

Electrical Specifications

(Ta = +25 °C, Vdd = +5VDC, f = as stated below, 75 Ω Differential Output)

Parameter	Min	Typ	Max	Units	Comments
Transimpedance Gain	500		10000	Ω	See Note 1
Transimpedance Gain Slope	-		+3	dB	See Note 1; from 87 to 1000 MHz
Optical-Electrical (OE) Gain		30		dB	Poptical = -15 dBm to 0 dBm; OMI = 3.7%; D1 Responsivity = 900 A/W; 87 to 1000 MHz
		42		dB	Poptical = -18 dBm to +3 dBm; OMI = 3.3%; D1 Responsivity = 900 A/W; 87 to 1000 MHz
EINC	-		2.0	pA/Square- Root-Hertz	Poptical = -15 dBm
	-		3.75	pA/Square- Root-Hertz	Poptical = -9 dBm
	-		4	pA/Square- Root-Hertz	Poptical = -6 dBm
	-		5.75	pA/Square- Root-Hertz	Poptical = 0 dBm
Output Return Loss (ORL)	-20			dB	See Note 1; 87 to 1000 MHz
Modulation Error Ratio (MER)	37			dB	See Note 2
	40			dB	See Note 2
OIP3	-	+24	-	dBm	See Note 2; F = 87 to 1000 MHz
	-	+34	-	dBm	See Note 3; F = 87 to 1000 MHz
Supply Current	-		135	mA	@ +5 Vdc; See Note 2
	-		185	mA	@ +5 Vdc; See Note 3
	-		100	mA	@ +12 Vdc; See Note 2
	-		150	mA	@ +12 Vdc; See Note 3

Notes: All specifications as measured using Duet evaluation assembly.

1. Measured in application circuit; Optical Input Power from +3 to -15 dBm, OMI 3.3%, 87-1000 MHz RF Bandwidth (BW).
2. Current Adjust Resistor Value = 40 Ω; Tested IAW SART Standard GY/T-300
3. Current Adjust Resistor Value = 10 Ω; Tested IAW SART Standard GY/T-300

Application Circuit for D1 +12 Vdc and VDD +5 Vdc Operation

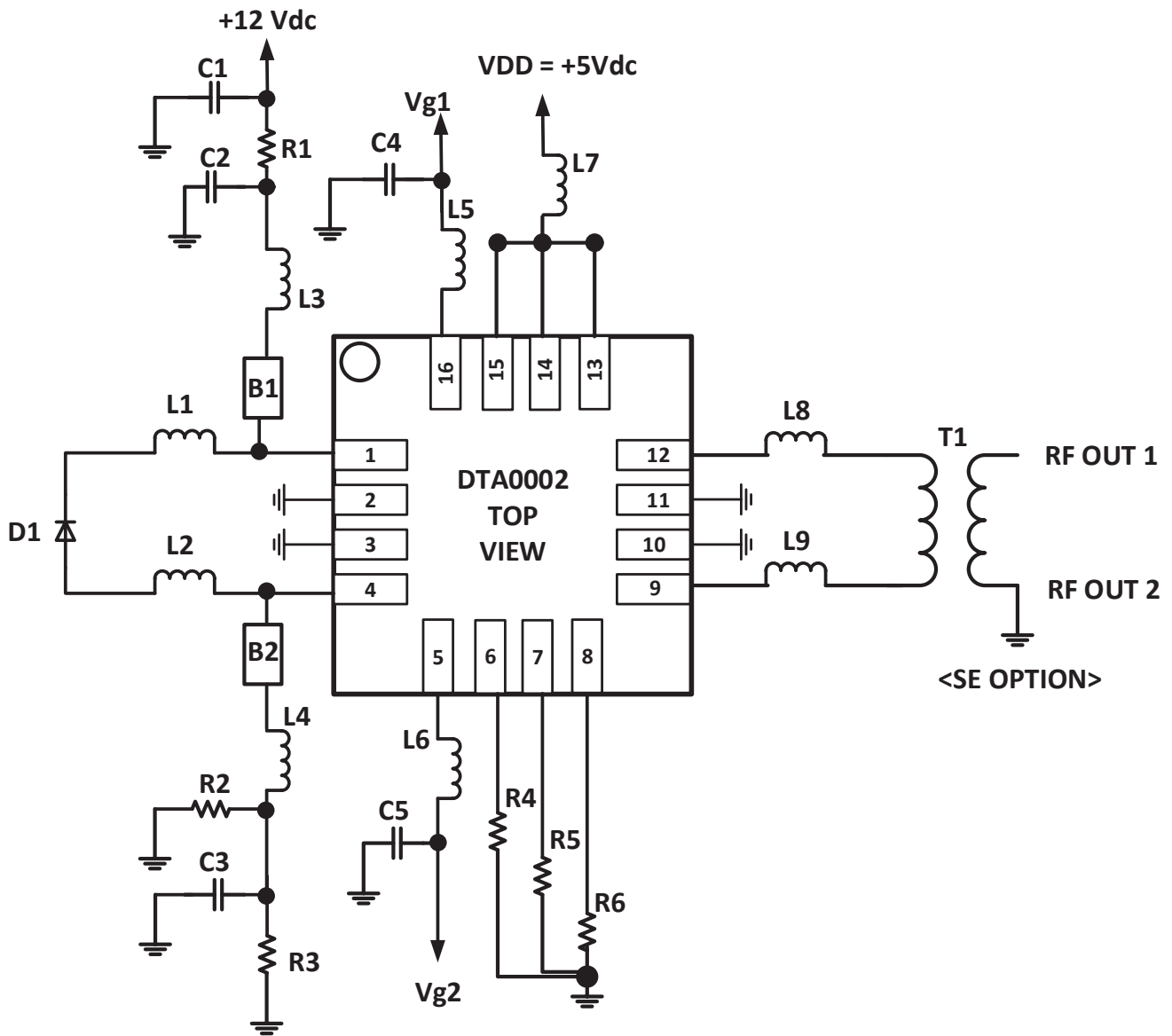

Bill of Material (BOM) for D1 +12 Vdc and VDD +5 Vdc Operation

Reference Designator	Value	Description	Manufacturer	Manufacturer Part Number
U1	Not Applicable	FTTx ORM	Duet Microelectronics	DTA0002
D1	Not Applicable	Photo Diode	Beijing SWT Optical Communication Technology Co., Ltd.	PDS123-CSA-C0103
T1	Not Applicable	1:1 RF Transformer	MACOM	MABA-007748-CT1160
L1, L2	16 nH	Wire-wound Inductor 0603	Coilcraft	0603CT-16NXJLU
L3, L4	880 nH	Inductor 1206 Ferrite Core Wirewound	MuRata	LQH31HNR88K
L5, L6, L7	500 nH	Inductor 1206 Ferrite Core Wirewound	MuRata	LQH31HNR50K
L8, L9	10 nH	Wirewound Inductor 0603	Coilcraft	0603CS-10NXJLU
C1, C2, C3, C4, C5	1 μ F	Capacitor Chip Ceramic 0603	MuRata	GRM188C81E105KAADD
B1, B2	0 Ω	Res Chip 0603	Panasonic	ERJ-3GEY0R00V
R1	1 K Ω	Res Chip 0603	Panasonic	ERJ-3EKF1001V
R2	200 Ω	Res Chip 0603	Panasonic	ERJ-3EKF2000V
R3	8.2 K Ω	Res Chip 0603	Panasonic	ERJ-3EKF8201V
R4, R5, R6	10 Ω	Res Chip 0603	Panasonic	ERJ-3EKF10R0V (NOTE)

Note: R4, R5, R6 = 10- Ω yields best MER with increase in total current consumption. Set R4, R5, and R6 = 40- Ω to achieve lowest current consumption (with degraded MER).

Application Circuit for D1 and VDD +12 Vdc Operation

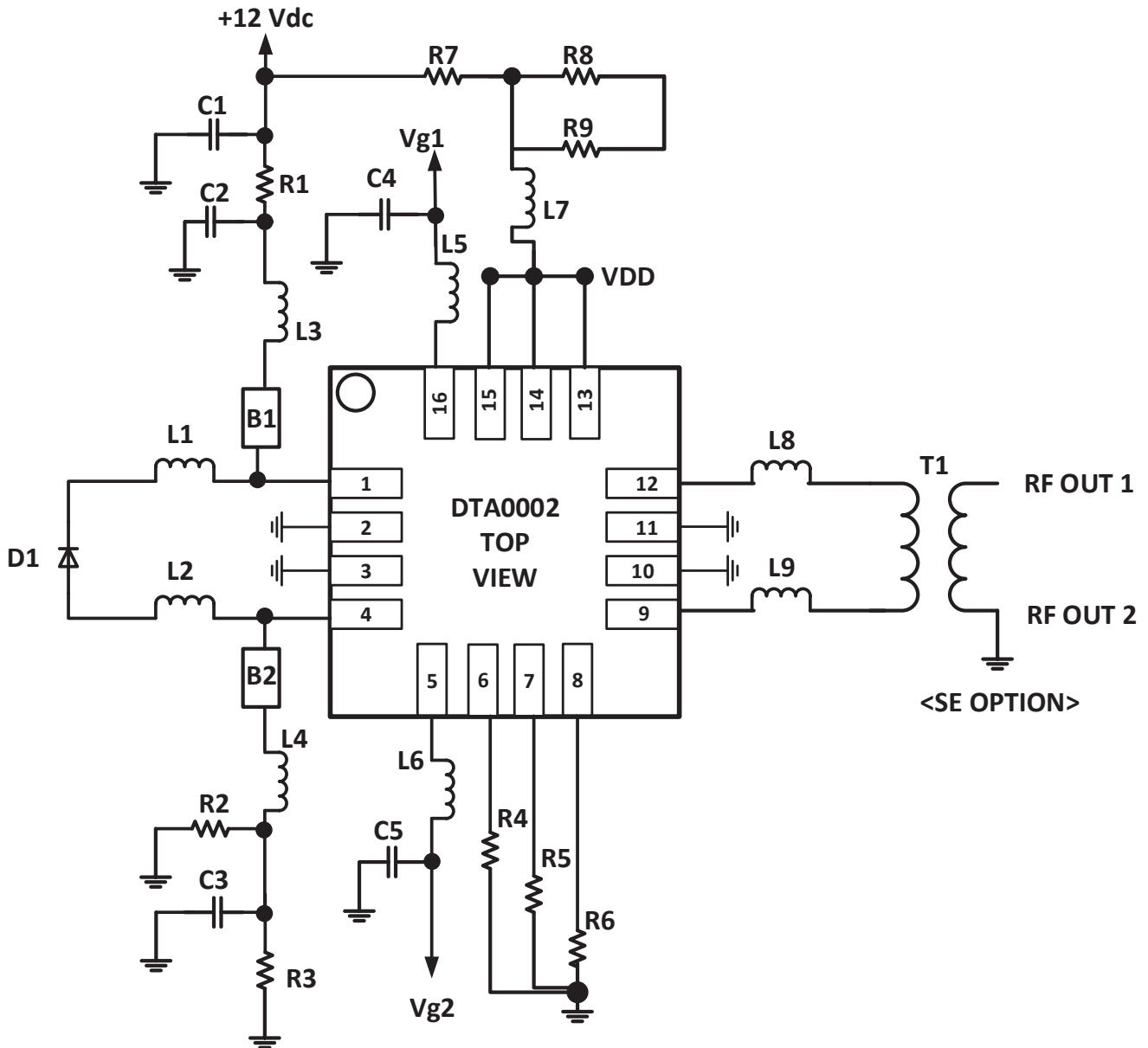

Bill of Material (BOM) for D1 and VDD +12 Vdc Operation

Reference Designator	Value	Description	Manufacturer	Manufacturer Part Number
U1	Not Applicable	FTTx ORM	Duet Microelectronics	DTA0002
D1	Not Applicable	Photo Diode	Beijing SWT Optical Communication Technology Co., Ltd.	PDS123-CSA-C0103
T1	Not Applicable	1:1 RF Transformer	MACOM	MABA-007748-CT1160
L1, L2	16 nH	Wire-wound Inductor 0603	Coilcraft	0603CT-16NXJLU
L3, L4	880 nH	Inductor 1206 Ferrite Core Wirewound	MuRata	LQH31HNR88K
L5, L6, L7	500 nH	Inductor 1206 Ferrite Core Wirewound	MuRata	LQH31HNR50K
L8, L9	10 nH	Wirewound Inductor 0603	Coilcraft	0603CS-10NXJLU
C1, C2, C3, C4, C5	1 μ F	Capacitor Chip Ceramic 0603	MuRata	GRM188C81E105KAADD
B1, B2	0 Ω	Res Chip 0603	Panasonic	ERJ-3GEY0R00V
R1	1 K Ω	Res Chip 0603	Panasonic	ERJ-3EKF1001V
R2	200 Ω	Res Chip 0603	Panasonic	ERJ-3EKF2000V
R3	8.2 K Ω	Res Chip 0603	Panasonic	ERJ-3EKF8201V
R4, R5, R6	10 Ω	Res Chip 0603	Panasonic	ERJ-3EKF10R0V (NOTE)
R8	2.55 K Ω	RES SMD 0.5% 1/4W 0603	Panasonic	ERJ-PA3D2551V

Note: R4, R5, R6 = 10- Ω yields best MER with increase in total current consumption. Set R4, R5, and R6 = 40- Ω to achieve lowest current consumption (with degraded MER).

Ordering Information

Order Number	Temperature Range	Package Description	Component Packaging
DTA0002P0	-40 to +100 °C	QFN-16 3x3 mm	Gel Pak, 1 to 100 each
DTA0002V0	-40 to +100 °C	QFN-16 3x3 mm	1500 each, T&R
DTA0002-PCB-5V	-40 to +100 °C	Evaluation Board +5Vdc	One Each
DTA0002-PCB-12V	-40 to +100 °C	Evaluation Board +12Vdc	One Each

Duet Microelectronics
575 Route 28, Suite 100
Raritan, NJ 08869 USA
1.908.854.DUET (3838)
info@duetmicro.com
www.duetmicro.com

Important Notice

Duet Microelectronics LLC reserves the right to make changes to its products or to discontinue any product at any time without notice. The product specifications contained in Advanced Data Sheets are subject to change prior to a product's formal introduction. Information in Data Sheets have been carefully checked and are assumed to be reliable; however, Duet Microelectronics assumes no responsibilities for inaccuracies. Duet Microelectronics strongly urges customers to verify that the information they are using is current before placing orders.

Warning

Duet Microelectronics products are not intended for use in life support appliances, devices or systems. Use of a Duet Microelectronics product in any such application without written consent is prohibited.